

FOR COMPLETE APPRECIATION OF THE FSK-1000,
READ THE MANUAL FIRST.

OPERATING MANUAL



FSK-1000 DEMODULATOR

CONTENTS

- I. Specifications
- II. Introduction and Background
- III. Control and Input/Output Descriptions
- IV. Operating and Interconnection Suggestions
- V. Circuit Description

WARNING: The FSK 1000 has 110 or 220 volt AC and 170 volt DC voltages present on the circuit board and at some rear panel connectors. Persons unfamiliar with or unqualified to service or operate equipment of this type should refer to a qualified electronics technician.

LIMITED WARRANTY

This iRL product is warranted against defects in workmanship or materials for a period of ninety (90) days from the date of purchase. Within this period, iRL will repair defective units without charge for parts or labor. This warranty does not cover transportation or shipping costs; nor does it cover equipment subjected to misuse or accidental damage. In no event, shall iRL be liable for losses incurred by the buyer in connection with the use of this equipment.

I. SPECIFICATIONS

MODE: limiterless (am) or hard limiting (fm)

SHIFT: continuously tunable, 50 to 1000 hertz

TONES: low 1275 to 2275 hertz
high 2125 to 3125 hertz (optional)

AUDIO INPUT: 600 ohm, unbalanced
minimum signal, 1 mv.
maximum signal, 17 volts (continuous)

OUTPUTS: 60 ma. 170 volt loop supply (adjustable)
RS 232 compatible "Data Out"
AFSK Out (on units with FSK-1020 keyer)
PTT "push to talk" switch output (open collector)

KEYBOARD INPUT: Serial input for RS 232 signals,
"dry" contacts, or TTL levels.
(mark= low voltage or closed contact,
space=high voltage or open contact)
maximum voltage, +12v

AUTOSTART: Dual mode (mark or FSK). Selectable 1 second
or 4 second attack time. Printer drop-out
in approximately 20 seconds.

POWER MAINS: 117 VAC 50 or 60 hertz, optional 220 VAC

DIMENSIONS: 5.22 inches high x 11.37 inches wide
x 10 inches deep

WARRANTY: 90 days against parts and workmanship



700 TAYLOR RD
COLUMBUS, OH 43230

614-864-2464

ATTENTION PLEASE

YOUR FSK-1000 IS BETTER THAN EVER!

The FSK-1000 has undergone some slight changes as the "second edition" comes off the line.

We have added some additional features making the FSK-1000 a better value than ever. Your current Operator's Manual will serve you well if you will please note some differences listed below.

- 1.) There has been an addition of a front panel mounted Threshold control, which is the small knob located just below the Input Level and ΔF controls. This control serves as an "RTTY Squelch" control and also sets the threshold for the autostart. Full sensitivity of the FSK-1000 occurs when this control is rotated fully counterclockwise.
- 2.) There is a new jack mounted on the rear panel directly below the "Audio In" jack. This is a "Remote T/R" jack. Shorting the center conductor to ground will place the FSK-1000 in a "hard" transmit mode. That is, the AFSK keyer will output a constant Mark and the PTT output will be enabled. This jack provides the operator with the means for connecting a remote SPST switch some distance from the FSK-1000 for transmitting and receiving without the Keyboard Activated Switch circuitry dropping out.
- 3.) The Tuning meters remain active in the Local mode.
- 4.) The Key-In jack is now a phono type jack which simply requires the grounding of the center conductor.
- 5.) The Key-In sends out a narrow shift (85 hz.) signal for CW ID.
- 6.) The keyboard or tape distributor (TD) of a mechanical teleprinter may be connected in series with the LOOP OUT and they will key the Keyboard Activated Switch and AFSK keyer. The Serial-In will NOT accept voltages over 12 volts.

II. INTRODUCTION AND BACKGROUND

Amateur radio has experienced tremendous growth in recent years and radioteletypewriter (RTTY) communications is one of the fastest growing aspects of the amateur radio service. The overall growth of the amateur ranks has been exciting in that it has been accompanied by significant technological advances which have provided hams with more sophisticated equipment and alternative modes of communication than ever before; however, with this growth has come an ever increasing congestion of powerful signals on the HF bands which makes solid communication over long distances heavily dependent upon highly selective receiving equipment that is capable of rejecting strong adjacent channel interference.

Although ideal demodulator characteristics, based on modern communication theory, have been described in the RTTY literature for years, the actual demodulators available to commercial and amateur radio operators have usually fallen considerably short of these ideals because a variety of technological or cost limitations often conspire to force compromises upon the actual design.

In the past, demodulators designed for commercial or government use have not had to deal with the problem of severe crowding ("QRM"), that is unique to amateur and MARS frequencies. Consequently, designer's concerns over selectivity were not addressed to the present day ham bands.

A consensus of the RTTY literature seems to suggest that the following are highly desirable features for an FSK demodulator.

- (a) Limiterless operation; necessitating stable, independent bandpass filters for each channel, wide dynamic range, and some form of decision level correction for optimum performance.
- (b) Matched characteristics of the bandpass filters for proper transient responses and noise cancellation.
- (c) Selectable bandwidth to accommodate different QRM conditions or higher baud rates such as is encountered with the use of 100 baud ASCII code instead of 45.45 Baudot code.
- (d) Tunable shifts, thereby accommodating signals whose shifts are slightly off or completely nonstandard.

Many demodulators, including phase locked loop types, use hard limiting front ends -- a technique which eliminates the requirements of (a) above and a host of other circuitry. The result is usually a simplified, easy-to-use demodulator which will function quite nicely on strong signals which are "in the clear" and not suffering from selective fading. Appropriately, limiter-type demodulators are fine for clear-channel signals such as one encounters on VHF or many commercial frequencies.

The price paid for using a limiter is that the ultimate selectivity of the demodulator is not as good as a limiterless design can attain, and the unit is subject to capture by the strongest input, be it the desired information or QRM. Also, selective fading (a relatively common occurrence on the HF bands) can cause the limiter to be captured by atmospheric noise (QRN) or QRM and produce printing errors.

The serious HF operator needs a limiterless demodulator, such as the FSK-1000.

The simultaneous achievement of items (b), (c) and (d) above has been one of the greatest challenges facing demodulator designers. The advent of active filters made it possible to mass produce highly selective filters with identical bandwidths and gains for any two specific frequencies; however, as with their passive forerunners, these filters did not allow independent tuning of parameters. Consequently, if the designer tried to change the filters' center frequency to achieve item (d), this adversely affected the filter's bandwidth and gain. Similarly, if he tried to change only the bandwidth to achieve item (c), he would simultaneously and unintentionally shift the center frequency and gain beyond acceptable limits. The cascading of more than one filter stage to achieve steeper skirt selectivity only intensified the existing problem.

One approach to satisfying (b) and (d) is to use two matched filters whose parameters are fixed. The incoming signals are then combined with a beat frequency oscillator in a mixer stage which shifts the incoming tones down to the fixed filter's center frequency. Thus, item (d) is achieved not by tuning the filter across the spectrum, but by changing the frequency of the oscillator.

There are two immediate drawbacks to this approach. First, the mixer stage produces sum and difference tones which can result in audio image interference which allows strong adjacent channel QRM to foul the desired signal. The effect can be to reduce the ultimate selectivity of the unit, in spite of using selective filters. The second drawback is that this approach ignores item (c) altogether.

The FSK-1000 meets all four of the listed criteria through the use of a limiterless design, and a modern, sixth order active filter arrangement which permits independent adjustment of the filter parameters to achieve (b), (c) and (d) without trading off the ultimate selectivity.

The FSK-1000 was designed from inception to function as a limiterless ("linear" or "AM") demodulator, eliminating errors which result from FM-type capture problems associated with hard limiting or "FM" demodulators. In the past, some demodulators have offered an "AM" mode which, while switching out the hard limiting front end, did not provide the operator with a positive indication that true linear operation was being achieved. Depending on the output levels of

the receiver, internal gains of the demodulator and dynamic range, it was often the case that high level received signals were being "soft" limited ("clipped") by operational amplifier stages driven into saturation. As a result, it was quite possible that many operators who thought they were operating in a limiterless mode, were actually suffering errors resulting from a type of limiter action.

The FSK-1000 is equipped with a front panel input level control and a dynamic range indicator LED which gives positive indication to the operator when the linear range is exceeded. This permits adjustment for true limiterless operation, "controlled clipping" or hard limiting if desired.

It is a common phenomenon on the HF bands for the mark and space tones of an FSK signal to exhibit independent fading, as if coming from two separate sources. This selective fading results from multipath propagation and can momentarily cause one of the tones to take a deep fade or disappear entirely. Selective fading can spell disaster for hard limiting demodulators since, in the absence of the desired tone, QRM or QRN will "capture" the limiter and produce a random output.

It takes a limiterless demodulator with some form of decision level correction to copy correctly with only one tone present. The FSK-1000 has automatic decision level correction which does not require the operator to switch correction in or out manually.

The FSK-1000 offers three switch-selectable standard shifts of 170, 425, and 850 Hz, while the front panel ΔF tuning allows continuous shift coverage from 50 to 1000 Hz in three ranges. The active filters in the FSK-1000 are computer designed for matched characteristics and optimum response at the standard shifts. The shift adjustments are made by actually tuning a multi-pole bandpass filter of constant bandwidth, rather than using audio frequency mixers in a heterodyning process. This assures complete freedom from audio images, spurious responses, or other problems associated with mixing techniques.

Selectable bandwidth filters for each tone allows the operator to select either 100 Hz "wide" channel filters for normal operation up to 110 baud, or 55 Hz ultra-narrow channel filters, designed specifically to slice through the tough QRM on the crowded HF amateur bands. The two bandpass filters utilize twenty FET operational amplifiers in a stable, modern topology.

The result is a demodulator which not only provides the HF operator with superior selectivity, but also maintains the flexibility one expects from a "deluxe" demodulator.

III. CONTROL AND INPUT/OUTPUT DESCRIPTIONS

FRONT PANEL CONTROLS

- ON/OFF: The ON/OFF switch applies power to the FSK-1000, including the AUTOSTART a.c. outlet on the rear panel.
- INPUT LEVEL: This control is adjusted while observing the LIMIT LED to select the optimum signal level for copying FSK signals. It has a full clockwise switch detent for the hard limiting mode and an auxiliary "pull" switch for use with the FSK-1040 video option or for any extra function the user may wish.
- NORMAL/REV: In the NORMAL position (out), the mark frequency is the lower of the two tones. The REV position (in) reverses the incoming information so that the higher tone is used as the mark. (This switch also reverses the function of the MARK/FSK/SPACE switch.)
- SHIFT, 850-425-170: These interlocking pushbuttons are used in conjunction with the ΔF control to select the desired shift range. With the ΔF set to its zero position and the 170 button depressed, the demodulator is set for 170 Hz operation. Rotation of the ΔF control permits adjustment of shift from 50 Hz to 270 Hz by tuning the space filter. With the 425 pushbutton depressed and the ΔF centered at zero, the demodulator is set for 425 Hz operation. Rotation of the ΔF control now permits adjustment of shift over the range of 260 to 640 Hz. Similarly, in the 850 shift position, the range of adjustment is from 590 Hz to 1000 Hz shift. The FSK-1000 equipped with the optional "high tones" has "170", "425", and "850" ΔF ranges of 50-250, 235-550, and 540-1000 Hz respectively.
- WIDE/NARROW: With the switch in the WIDE position (out), the bandwidth of the tone channels is 100 Hz nominal. With the switch in the NARROW position (in), the bandwidth is 55 Hz nominal.

LINE/LOCAL: With the switch in the LINE position (out), the demodulator is in its normal mode for receive and transmit operation. With the switch in the LOCAL position, (in), the audio input to the demodulator is grounded, and the optional FSK-1020 AFSK keyer is disabled. Also, the PTT ("push-to-talk") is disabled so that the operator may type on his keyboard and observe local copy without keying his transmitter.

LIMIT: This LED illuminates when the audio input level has reached the point where limiting begins in the demodulator. This indicator enables the operator to adjust for the optimum signal level in the limiterless or "linear" range.

TUNING METERS: These meters indicate the relative signal strengths of the two-tone channels and are viewed by the operator when tuning in an RTTY station. The MARK TUNING meter indicates the strength of the lower FSK tone, while the SPACE TUNING meter indicates the strength of the higher tone. If the reverse button (REV) is pushed, then the signal displays are reversed.

MARK/FSK/SPACE: This three position toggle switch is normally set to the middle position which is for full FSK operation. Throwing the switch up to the MARK position removes the signal from the space channel completely to allow for mark-only copy. Setting the switch down to the SPACE position, removes the signal from the mark channel to allow for space-only operation. The NORMAL/REV switch reverses the operation of this switch.

AUTOSTART: ON/OFF: With this switch in the OFF position (out), the autostart function is disabled and power is constantly applied to the rear panel autostart power outlet, controlled by the power ON/OFF switch. With the switch in the ON position (in), the autostart function is enabled.

AUTOSTART: FSK/MARK: With the switch in the FSK position (out), the autostart responds to FSK signals (both tones must be shifting) which are above the autostart threshold, and will not trigger on a constant tone in either channel. With the switch in the MARK position (in), the autostart will trigger on a mark tone signal and shifting FSK tones are not required.

AUTOSTART: FAST/SLOW: With the switch in the FAST position (out), the attack time is approximately one second. With the switch in the SLOW position (in), the attack time is approximately four seconds. The attack times may be changed by installation of new resistors on the circuit board.

REAR PANEL JACKS

AUDIO IN:

This phono jack receives audio from the receiver. The input impedance is nominally 600 ohms, unbalanced. Although some receivers provide 500 - 600 ohm outputs, a common practice is to simply connect across the receiver's speaker terminals.

SERIAL IN:

This phono jack input is for connection of a serial output keyboard or tape reader. The keyboard output may consist of "dry contacts" (such as from a mechanical keyboard without loop current), or RS-232 voltages (mark = -12V max, space = +12V max) or TTL levels (mark = 0V, space = +5V). THIS JACK DOES NOT ACCEPT HIGH VOLTAGE (greater than $\pm 12V$) LOOP SUPPLIES. This input does, however, drive the 170 volt LOOP OUTPUT in the FSK-1000, so that local copy can be observed on a mechanical teleprinter even though the keyboard is not actually in the high voltage loop. This was done so that a variety of keyboard inputs such as RS-232) could be converted to a high voltage loop output. Dry contacts should be closed for mark and open for space. IF THE SERIAL IN IS NOT TO BE USED, THEN A SHORTING-TYPE PHONO PLUG JUMPER IS REQUIRED IN THIS JACK. Otherwise, the demodulator will not function.

+170 POLARIZED LOOP: This one-quarter-inch three-conductor phone jack provides a high voltage, 60 mA polarized loop current output for driving mechanical teleprinters. The output information is either the demodulated receiver audio or that information which is inputted to the SERIAL IN jack. The tip of the three-conductor phone plug is (+) and the ring (center conductor) of the plug is the (-). The main barrel of the plug is chassis ground and may be used for connecting a shield, if a shielded, twisted pair loop cable is used. The loop current may be adjusted for 20 mA operation. This may be accomplished by adjusting the slide on the large power resistor (R301) at the left rear of the circuit board. The slide should be moved upwards to lower the current. The loop current should be measured by an ammeter placed in series with the loop. **POWER SHOULD BE REMOVED BEFORE ADJUSTING THE SLIDE. THE SLIDE IS CONNECTED TO 170 VOLTS DC AND PRESENTS A SHOCK HAZARD.** A two-conductor phone plug will not function in this jack. The three-conductor jack was used to lessen the likelihood of electrical shock at the LOOP OUT.

DATA OUT: This phono jack provides a RS 232 compatible output (mark = -11V nom., space = +11V nom.). The output information is either the demodulated receiver audio or the information inputted to the SERIAL IN jack. Thus, this jack outputs the same information as the LOOP OUT and may be used simultaneously with the loop out. For instance, the DATA OUT jack may be used to drive a computer or video character generator while the LOOP OUT drives a tape punch or "hard copy" terminal. The DATA OUT jack may be strapped for TTL compatible outputs (mark = 0V, space = 5V, or mark = +5V, space = 0V).

*mark
low*
*space
high*

PTT OUT: This phono jack is for use with the "push-to-talk" lines of many transmitters. The output consists of an open-collector transistor output which is driven "on" (pulled low) by the keyboard activated switch in the FSK-1000. Upon depressing a character on the keyboard (or closing a hand key connected to KEY IN), the transistor turns on, effectively grounding the PTT line. The transistor has a rated maximum of 40 volts and 60 mA. Users should determine if the push-to-talk voltage in their transmitter exceeds this rating. If so, an external relay may be required to isolate this output. This jack may not be required if the transmitter has provision for VOX operation, in which case the audio tones from the AUDIO OUT would key the transmitter. This jack is totally disabled when the FSK-1000 is in the LOCAL mode.

SCOPE OUT MARK,
SCOPE OUT SPACE:

These two phono jacks provide access to the bandpass filter outputs (output impedance is approximately 100K) for use with an external oscilloscope tuning indicator. The maximum output voltage is 12 volts. Adventurous operators are encouraged to connect the outputs to a stereo amplifier for driving stereo headphones for use as an audio tuning indicator or highly selective CW filter. (An attenuator would probably be required at the input of the amplifier since the SCOPE outputs are high level.)

KEYBOARD PARALLEL:

This 25-pin subminiature "D" connector is for units which have the FSK-1040 Video option and is for connection of a parallel ASCII keyboard. A parallel keyboard connected to an FSK-1000 with FSK-1040 enables the operator to send either ASCII or BAUDOT codes from the same keyboard. This connector is for a parallel output keyboard (with strobe) and should not be confused with RS-232 type connectors which are for serial interfaces.

VIDEO OUT:

This phono jack output is for use with FSK-1000 demodulators which have the FSK-1040 video option installed. It provides standard composite video for driving video monitors.

KEY IN:

This one-quarter-inch three-conductor phone jack is for connection of a standard hand key, for full-shift CW identification or manual tests of the mark and space outputs. Normally, when receiving, the key contacts should be open. Closing the key activates the keyboard activated switch and causes a space to be sent. When the key is opened again the demodulator goes to the mark condition until the keyboard switch "times out" (approximately three seconds). The key should be connected to the tip and ring of a three conductor phone jack.

AFSK OUT:

(This phono jack is for units which have the optional FSK-1020 AFSK keyer installed.) The output consists of audio tones for driving the microphone input of a transmitter. The keyer is enabled by the keyboard activated switch and shifts in accordance with the information inputted to the SERIAL IN. The keyer is completely disabled when the demodulator is in the LOCAL position.

CODE: BAUDOT/ASCII: This switch is for demodulators with the FSK-1040 video option installed. It permits the video monitor to display ASCII or BAUDOT information, and for stations equipped with a parallel ASCII keyboard. It permits the sending of either BAUDOT or ASCII from the keyboard. (The baud rates are selected by the front panel "push/pull" switch located on the INPUT LEVEL control.

The circuit board is easily accessible by removing the two screws at the top of the rear panel and sliding the top out.

IV. OPERATING AND INTERCONNECTION SUGGESTIONS

INTERCONNECTIONS

The FSK-1000 is somewhat different than most demodulators. In certain circumstances, particularly when QRM is a problem, the FSK-1000 is capable of providing significantly improved copy over that of many demodulators.

With this potential for improved performance, however, goes a requirement for improved operator skills.

The operator is encouraged to experiment with various combinations of control settings on his receiver and demodulator in order to "get the feel" of what the unit can do. Also, the operator should read some of the RTTY literature available from various radio publishing houses, to acquaint himself with the general requirements of an RTTY station. Such things as filter bandwidths, BFO or passband settings, signal speeds and keying techniques are dealt with extensively in these handbooks, as well as suggestions for station interconnections and explanations of many RTTY terms.

Just as the chain is only as strong as its weakest link, an RTTY station requires a good, stable, properly adjusted receiver and transmitter, a good antenna, a reliable teleprinter, and most importantly, an operator who is knowledgeable about how the whole system "plays" together.

The basic receive setup is shown in Figure IV-1 and is quite simple. Please note that normally, a shorting plug is required in the SERIAL IN when nothing is connected to it. If an RS-232 output level (or TTL level with appropriate straps) is required, the output should be taken from the DATA OUT jack. The basic transmit connections are shown in Figure IV-2 and include connections for demodulators with the FSK-1020 AFSK keyer option installed. For demodulators without a keyer, there is nothing connected to the AUDIO OUT jack, and transmitter keying must be effected through other means. The operator should consult his transmitter operating manual to determine the type of connector and pin connections necessary to input the signal from the AUDIO OUT jack and the PTT OUT jack.

OPERATION

For initial operation of the FSK-1000, the controls should be set to the following positions.

INPUT LEVEL:	Full counterclockwise (minimum)
ON/OFF:	ON
MARK/FSK/SPACE:	FSK (center position)
NORMAL/REV:	NORMAL
^F:	Zero (12 o'clock position)
SHIFT:	To anticipated shift; 170, 425, or 850
WIDE/NARROW:	WIDE
AUTOSTART ON/OFF:	OFF (out)
AUTOSTART FAST/SLOW	FAST (out)
AUTOSTART/FSK/MARK:	FSK (out)
LINE/LOCAL:	LINE

Tune the receiver until an FSK signal is heard and adjust the receive audio level for a comfortable listening volume. Next, slowly rotate the INPUT LEVEL control clockwise until a point is reached where the LIMIT indicator light begins to turn ON. (It may "blink" on and off with receiver static if you are set right at the threshold).

The LIMIT indicator lights to signal the operator that the input level is exceeding the limiterless (or linear) range and that limiting of the signal is beginning to take place.

Now, reduce the INPUT LEVEL control slightly just to the point where the LIMIT indicator goes off. At this point the operator has the maximum input level possible for limiterless operation.

Next, tune the receiver up and down SLOWLY through the RTTY frequency until a noticeable peak is observed on BOTH tuning meters. This peak is quite sharp, so tune carefully. If the demodulator is set for the correct shift, both meters will peak simultaneously at about 75 percent of full scale when the signal is properly tuned in. Intelligent copy should now be observed on the teleprinter. If not, it may be that the received tones are reversed (the low tone is the space, and the high tone is the mark).

If this is the case, the situation can be corrected by setting the NORMAL/REV switch to REV (in).

During the course of printing, the RTTY signal may be heard or seen to fade momentarily. It is not usually necessary to readjust the INPUT LEVEL control for this signal as the FSK-1000 is capable of copying signals which barely deflect the meters at all. Also, if the INPUT LEVEL control is increased during a momentary fade, limiting may occur when the signal returns to its previous strength. Normally, "soft clipping" as indicated by sporadic "blinks" of the LIMIT indicator is of little concern. Remember too, that the input level may be adjusted by either the INPUT LEVEL control or the receiver's audio gain control.

Full limiting operation is achieved by rotating the input level control to the full clockwise position until it "clicks" into the switch detent. Although the unit is designed primarily for limiterless operation, the limiter mode works well on good signals which are "in the clear" and makes tuning somewhat easier, because of the fact that the tuning meters give maximum deflection on almost all signals.

limit full

For copying stations in the midst of strong adjacent channel interference (QRM), limiterless operation is a must and the LIMIT indicator should be completely OFF. Also, copy may be significantly improved by switching the WIDE/NARROW pushbutton to the NARROW position.

The NARROW filters are extremely sharp and require that the operator exercise extreme care in tuning. Slight mistuning due to operator judgement or a drifting signal can have adverse effects on performance. The NARROW position is generally recommended for use with 60 word-per-minute BAUDOT code (45.45 baud); however, it may prove beneficial in circumstances where QRM is interfering with good signals up to 110 baud.

On a crowded band, a situation may occur where a strong CW station or off-frequency RTTY station may be transmitting "on top" of either the mark or the space frequency. The only recourse for the operator in this situation is to switch the MARK/FSK/SPACE toggle switch up or down to see if copy can be obtained from one tone only. One-tone-only copying is not possible when limiting is occurring. Also, since in this mode, the operator has literally "thrown out" half of the signal, it generally takes a better than average signal-to-noise ratio in the remaining channel to produce copy. For RTTY work on the HF bands, there is rarely a case for using anything other than the FSK mode. The one-tone modes are included, however, so that the serious operator immersed in a battle with QRM, will not have to throw up his hands in defeat until all possible techniques have been attempted.

Mark-only operation can be advantageous on VHF FM, if the FSK-1000 is equipped with the standard "low tones" and the operator wishes to receive information sent via "high tones". The procedure would be as follows:

1. Set the SHIFT for 850 Hz. This would normally mean that the mark channel is set for 1275 Hz and the space channel for 2125 Hz.
2. Set the NORMAL REV switch to REV for reverse operation. This then places the 2125 Hz signal in the mark channel.
3. Set the MARK/FSK/SPACE switch for SPACE (down). This eliminates noise from the 1275 Hz filter, which is not used in this case.
4. Be sure the INPUT LEVEL control and receiver audio are adjusted for limiterless operation.

TRANSMITTING

A serial keyboard (or tape reader, computer output, etc.) will activate the keyboard activated switch circuitry immediately upon the transmission of a character. The serial input overrides the audio input and causes the character to be generated at the LOOP OUT and the DATA OUT jacks. At the same time, the PTT jack goes to ground and the AFSK keyer (if installed) is enabled. Since most transmitters or transceivers require several milliseconds to change over to transmit, the first RTTY character may be lost. Therefore, it is usually a good idea to send one or two "LTRS" characters (or tap the "space" bar) to begin a transmission. Once typing (or tape reading) has ceased, the keyboard activated switch will drop back to the receive mode after approximately three seconds.

Full-shift manual keying may be accomplished with a standard hand key connected to the KEY IN input. The normal condition of the key should be open. Closing the key will operate the keyboard activated switch, sending the higher tone with the key closed and the lower tone with the key open.

With the LINE/LOCAL switch set to LOCAL, the AFSK keyer and PTT OUT are not enabled by the keyboard activated switch.

AUTOSTART OPERATION

The FSK-1000 AUTOSTART may be used to turn a teleprinter or other station accessory "on" automatically by means of the switched AC outlet located on the rear panel. For normal autostart operation the AUTOSTART pushbuttons should be set as follows.

1. AUTOSTART ON/OFF: ON (in)
2. AUTOSTART FAST/SLOW: FAST (out)
3. AUTOSTART FSK/MARK: FSK (out)

In this mode of operation, it takes an FSK signal which deflects both tuning meters past half-scale for approximately one second. The INPUT LEVEL control should be adjusted so that in the absence of a desired RTTY signal, the meters tend to stay below half-scale. The FSK-1000 requires a frequency-shifting signal in both channels and both channels must be above half-scale. Consequently, the autostart rejects constant CW tones of any amplitude and most random QRM. Once the autostart has turned on, it will stay on until 20 seconds after the RTTY signal has either disappeared or fallen below the threshold.

Although the threshold (approximately mid-scale) is factory adjusted, the user may adjust the threshold by means of a screwdriver adjustable potentiometer, accessible at the rear of the panel. Clockwise rotation

of this pot lowers the autostart threshold to less than half-scale, and counterclockwise rotation increases the threshold to above half-scale. The operator is encouraged to experiment with various INPUT LEVEL settings, and attack times to achieve the desired autostart response before attempting to adjust the threshold pot.

Selecting AUTOSTART: SLOW (in) changes the attack time from one second to four seconds. Selecting AUTOSTART: MARK (in) means that a mark signal alone which is above the threshold will turn on the autostart.

SERVICE

If difficulty is experienced with the operation or interconnection of your demodulator, iRL Engineers are available for limited technical consultation by telephone or correspondence, at no extra charge. For repair work performed outside of the iRL limited warranty, iRL charges a fee of Fifteen Dollars (\$15.00) per hour plus the cost of any parts which may be required. (Most minor repairs to demodulators are accomplished in one hour or less.)

iRL does not pay shipping charges, and will ship United Parcel Service C.O.D., unless specifically instructed otherwise.

All information provided by iRL is believed to be accurate and reliable; however, no responsibility is assumed by iRL for its use; nor for any infringements of patents or rights of third parties which may result from its use. No license is granted by implication or otherwise under any patent or patent rights of iRL.

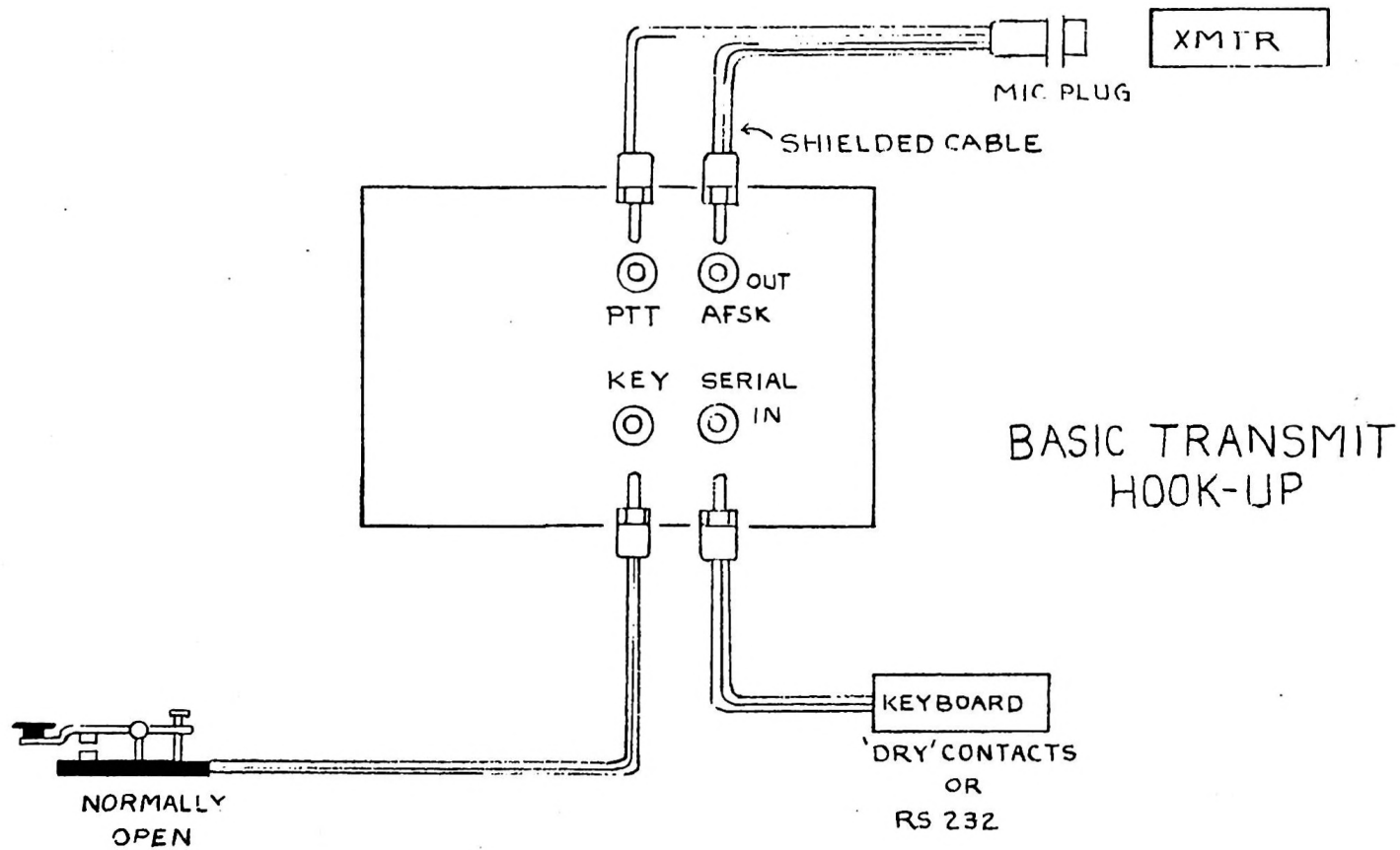

FIGURE IV-2

V. CIRCUIT DESCRIPTION

Audio taken from the receiver speaker output or 500-ohm audio output is applied to the input amplifier where the signal level can be attenuated or increased by adjustment of the INPUT LEVEL potentiometer. The LIMIT level detector circuitry samples the output of the input amplifier and the LIMIT indicator lights when this output approaches the saturation point. The limit detector circuitry consists of U23B configured as a comparator and U23A as a unity gain, noninverting amplifier. Transistor Q1 drives the front panel LIMIT LED. LINE/LOCAL switch, S-9, shorts the output of the input amplifier in the LOCAL position to prevent audio signals from producing copy at the output. Center-off toggle switch, S-10, (MARK/FSK/SPACE) selects for mark only, space only, or FSK inputs by appropriate grounding of the undesired channel.

The bandpass filters are sixth order transitional Butterworth-Thomson filters. From the schematic, it can be seen that each filter consists of three identical filter sections arranged in a modified cascade form known in the literature as a multiple resonator topology. The individual filters sections are of the bi-quad type and are well known for stability, constant bandwidths, high Q's and ease of tuning.

Switch S-5 (WIDE/NARROW) changes the feedback between sections to select the narrow bandwidth. The filters have a gain of unit.

The SCOPE outputs are taken directly off the bandpass filter outputs, isolated by a 100K resistor.

The outputs of the bandpass filters are envelope-detected by passing the signals through precision rectifiers followed by low-pass filters. The low-pass filtering is that of a fourth order Bessel-type which rolls off at 50 Hz.

The output of the low-pass is applied to the main summer (U19) where it is combined with signals from the decision level correction circuitry.

The keyboard activated switch injects data from the SERIAL IN into the data stream here, through use of FET Q6. A DC offset nulling pot is also summed into U19A to compensate for operational amplifier offsets.

The decision level correction circuitry (DLCC), automatically biases the main summer so that the input decision level, about which the summer's output is driven either positive or negative, is always centered halfway between the peak mark and space amplitudes. It is this circuitry which enables the FSK-1000 to copy RTTY signals when only one tone is present or where selective fading of the tones occur.

The tuning meters are driven by voltage followers U15A and U16A which receive their inputs from the DLCC circuitry.

The output of the main summer is applied to U19B, configured as an inverting comparator with about 24 millivolts of hysteresis. The output of the comparator then drives the high voltage loop supply and the DATA OUT driver. The loop current is adjusted by the large slide potentiometer, R301 for 60 mA operation. CAUTION: THE LOOP SUPPLY POT SHOULD NEVER BE ADJUSTED WITH THE POWER APPLIED TO THE DEMODULATOR, SINCE THE 170 VOLTS PRESENT ON ITS TERMINALS PRESENTS A SHOCK HAZARD TO THE INDIVIDUAL. Even after power is removed, time should be allowed (approximately ten seconds) for the 180-volt capacitor to discharge.

The SERIAL IN drives U24B, which is normally wired as a high impedance comparator, whose reference voltage is determined by the voltage divider R137, R138. Keying signals are then routed to the FSK-1020 AFSK keyer via the shift-select pushbuttons and a dual-in line header with ribbon cable.

Autostart voltages are "picked off" at the DLCC stage. When capacitors C54 and C55 both charge to voltages greater than the reference set by the AUTOSTART threshold adjust, then the output of U20 "snaps" high, charging C58 which ultimately causes the autostart to function.

Autostart attack times are determined by R123 (FAST) and R122 (SLOW). The autostart dropout time is determined by C56 and R114.

FSK 1000A PARTS LIST

RESISTORS

R1	620	R50	2.15K(5.90K)	R100	46.4K	R150	1.00K
R2	4.99K	R51	80.6K	R101	20.0K	R151	10.0K
R3	4.99K	R52	317K	R102	20.0K	R152	562
R4	4.99K	R53	10.0K	R103	20.0K	R153	562
R5	620½W	R54	10.0K	R104	46.4K	R154	10MEG
R6	105K	R55	10.0K	R105	20.0K	R155	4.99K
R7	6.49K	R56	13.3K	R106	5.90K	R156	46.4K
R8	20.0K	R57	105K	R107	20.0K	R157	46.4K
R9	105K	R58	2.15K(5.90K)	R108	10.0K	R158	105K
R10	1.69K(3.57K)*	R59	105K	R109	105K	R159	4.99K
R11	1.30K(1.96K)	R60	317K	R110	10.0K	R160	3.57K
R12	845 (1.30K)	R61	10.0K	R111	6.49K	R161	4.99K
R13	80.6K	R62	10.0K	R112	10.0K	R162	317K
R14	317K	R63	10.0K	R113	Deleted	R163	36.2K
R15	10.0K	R64	13.0K	R114	317K	R164	100K½W
R16	10.0K	R65	105K	R115	10.0K	R165	10.0K
R17	10.0K	R66	2.15K(5.90K)	R116	20.0K	R166	10MEG
R18	13.3K	R67	317K	R117	20.0K		
R19	105K	R68	317K	R118	Deleted		
R20	1.69K(3.57K)	R69	10.0K	R119	Deleted		
R21	1.30K(1.96K)	R70	10.0K	R120	10.0K		
R22	845 (1.30K)	R71	10.0K	R121	562		
R23	105K	R72	24.9K	R122	499K		
R24	317K	R73	10.0K	R123	71.5K		
R25	10.0K	R74	4.99K	R124	562		
R26	10.0K	R75	10.0K	R125	20.0K		
R27	10.0K	R76	10.0K	R126	10.0K		
R28	13.0K	R77	4.99K	R127	10.0K		
R29	105K	R78	1.96K	R128	562½W		
R30	1.69K(3.57K)	R79	10.0K	R129	332		
R31	1.30K(1.96K)	R80	48.7K	R130	100K½W		
R32	845 (1.30K)	R81	61.9K	R131	10.0K		
R33	317K	R82	105K	R132	10.0K		
R34	317K	R83	154K	R133	1.96K		
R35	10.0K	R84	36.5K	R134	Deleted		
R36	10.0K	R85	46.4	R135	10.0K		
R37	10.0K	R86	56.2K	R136	317K		
R38	24.9K	R87	105K	R137	10.0K		
R39	105K	R88	10.0K	R138	56.2K		
R40	105K	R89	Deleted	R139	154K		
R41	10.0K	R90	10.0K	R140	10.0K		
R42	4.99K	R91	Deleted	R141	317K		
R43	10.0K	R92	317K	R142	105K		
R44	10.0K	R93	154K	R143	4.99K		
R45	4.99K	R94	317K	R144	4.99K		
R46	105K	R95	Deleted	R145	1.30K		
R47	6.49K	R96	46.4K	R145A	1.00K		
R48	20.0K	R97	2MEG	R146	10.0K		
R49	105K	R98	10.0K	R147	4.99K		
		R99	Deleted	R148	4.99K		
				R149	20.0K		

CAPACITORS

C1	.1uF
C2	.1uF
C3	.015uF
C4	.015uF
C5	.015uF
C6	.015uF
C7	.015uF
C8	.015uF
C9	.015uF
C10	.015uF
C11	.015uF
C12	.015uF
C13	.015uF
C14	.015uF
C15	.047uF
C16	.015uF
C17	.1uF
C18	.015uF
	(Polarized)
C19	.1uF 25WVDC
C50	4700uF 25WVDC
C51	4700uF 25WVDC
C52	100uF 250WVDC
C53	THRU C62
	10uF 225WVDC

* () These symbols designate resistors used in low tone FSK 1000.

POTENTIOMETERS

R401 1MEG
R402 500 (2K)
R403 100K

TRIMMERS

R200 500 (2K)
R201 500 (2K)
R202 500
R203 500 (2K)
R204 500 (2K)
R205 500
R206 500 (2K)
R207 500 (2K)
R208 500
R209 500 (2K)
R210 500 (2K)
R211 500 (2K)
R212 2K
R213 DELETED
R214 2K
R215 2K

DIODES

D1 THRU D33 1N4148
Z1 1N750 4.7V

BRIDGE RECTIFIER

BR1 MDA104A
BR2 MDA104A

INTEGRATED CIRCUITS

U1 THRU U12 TLO82, LF353 or MC34002
U13 THRU U25 MC1458, TLO82 or MC34002

TRANSISTORS

Q1, Q3, Q5, Q7 2N2222
Q2 (FET) 2N5458

REGULATORS

VR1 MC7812CT
VR2 MC7912CT

RELAY

K1 28H113AE

FSK 1020A PARTS LIST

RESISTORS

R1 1K
R2 100K
R3 100K
R4 100K
R5 100K
R6 100K
R7 100K
R8 100K
R9 100K
R10 100K
R11 100K
R12 100K
R13 1.5MEG
R14 100K
R15 100K
R16 Deleted
R17 8.06K
R18 Jumper
R19 1.5MEG
R20 4.99K
R21 4.99K
R22 4.99K
R23 15.8K
R24 11.8K
R25 11.8K
R26 11.0K
R27 1.96K
R28 10.0K
R29 1.96K
R30 9.35K
R31 1.47K
R32 7.68K
R33 Deleted
R34 5.62K
R35 1.00K
R36 10.0K

CAPACITORS

C1 .015uF
C2 .033uF
C3 .0047uF
C4 .015uF
C5 .015uF
C6 .001uF
C7 .1uF

DIODES

D1 THRU D6 1N4148

INTEGRATED CIRCUITS

A1 CD4066BE
A2 CD4066BE
A3 MC1458P
A4 MC1458P
A5 MC1458P
A6 MC1458P

TRIMMERS

R100 Deleted
R101 2K
R102 2K
R103 2K
R104 2K
R105 500
R106 500
R107 2K



FSK-1000

RESISTORS

R1	620	R100	46.4K
R2	1.0K	R101	10.0K
R3	4.99K	R102	20.0K
R4	4.99K	R103	20.0K
R5	620Ω	R104	46.4K
R6	105K	R105	10.0K
R7	105K	R106	4.99K
R8	20.0K	R107	20.0K
R9	20.0K	R108	20.0K
R10	105K	R109	10.0K
R11	1.49K(3.57K)*	R110	10.0K
R12	1.30K(1.96K)	R111	10.0K
R13	80.4K(1.30K)	R112	10.0K
R14	317K	R113	Deleted
R15	317K	R114	317K
R16	10.0K	R115	10.0K
R17	13.3K	R116	20.0K
R18	10.0K	R117	20.0K
R19	10.0K	R118	Deleted
R20	105K	R119	Deleted
R21	1.49K(3.57K)	R120	10.0K
R22	1.30K(1.96K)	R121	10.0K
R23	815(1.30K)	R122	4.99K
R24	10.0K	R123	71.5K
R25	10.0K	R124	562
R26	10.0K	R125	20.0K
R27	10.0K	R126	10.0K
R28	10.0K	R127	10.0K
R29	13.0K	R128	562Ω
R30	105K	R129	332
R31	1.49K(3.57K)	R130	100KΩ
R32	1.30K(1.96K)	R131	10.0K
R33	815(1.30K)	R132	1.96K
R34	317K	R133	1.96K
R35	10.0K	R134	Deleted
R36	10.0K	R135	46.4K
R37	10.0K	R136	317K
R38	10.0K	R137	10.0K
R39	21.9K	R138	36.2K
R40	105K	R139	154K
R41	105K	R140	10.0K
R42	10.0K	R141	10.0K
R43	4.99K	R142	105K
R44	10.0K	R143	4.99K
R45	4.99K	R144	317K
R46	105K	R145	Deleted
R47	6.49K	R146	46.4K
R48	20.0K	R147	10.0K
R49	105K	R148	4.99K
R50	105K	R149	20.0K

POTENTIOMETERS

VR1	MC7912
VR2	MC7812

TRIMMERS

T200	500 (2K)
T201	500 (2K)
T202	500 (2K)
T203	500 (2K)
T204	500 (2K)
T205	500 (2K)
T206	500 (2K)
T207	500 (2K)
T208	500 (2K)
T209	500 (2K)
T210	500 (2K)
T211	500 (2K)
T212	500 (2K)
T213	Deleted
T214	Deleted
T215	Deleted
T216	Deleted
T217	Deleted
T218	Deleted
T219	Deleted
T220	Deleted

DIODES

D1	THRU D33	1N4148
Z1		1N750 4.7V

BRIDGE RECTIFIER

BR1	HDA10A
BR2	HDA10A

INTEGRATED CIRCUITS

U1	THRU U11	TL082, LF353 or MC34002
U13	THRU U23	MC1458, TL082 or MC34002

TRANSISTORS

Q1	Q3, Q5, Q7	2N2222
Q2	(FET)	2N5458

REGULATORS

VR1	MC7812C1
VR2	MC7912C1

RELAY

K1	28H113AE
----	----------

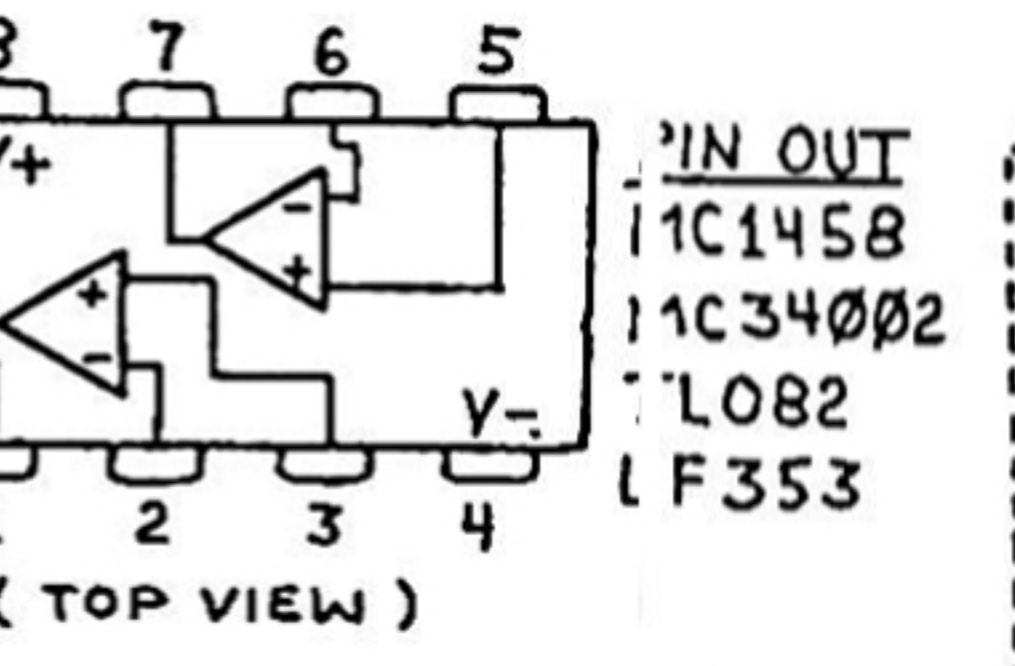
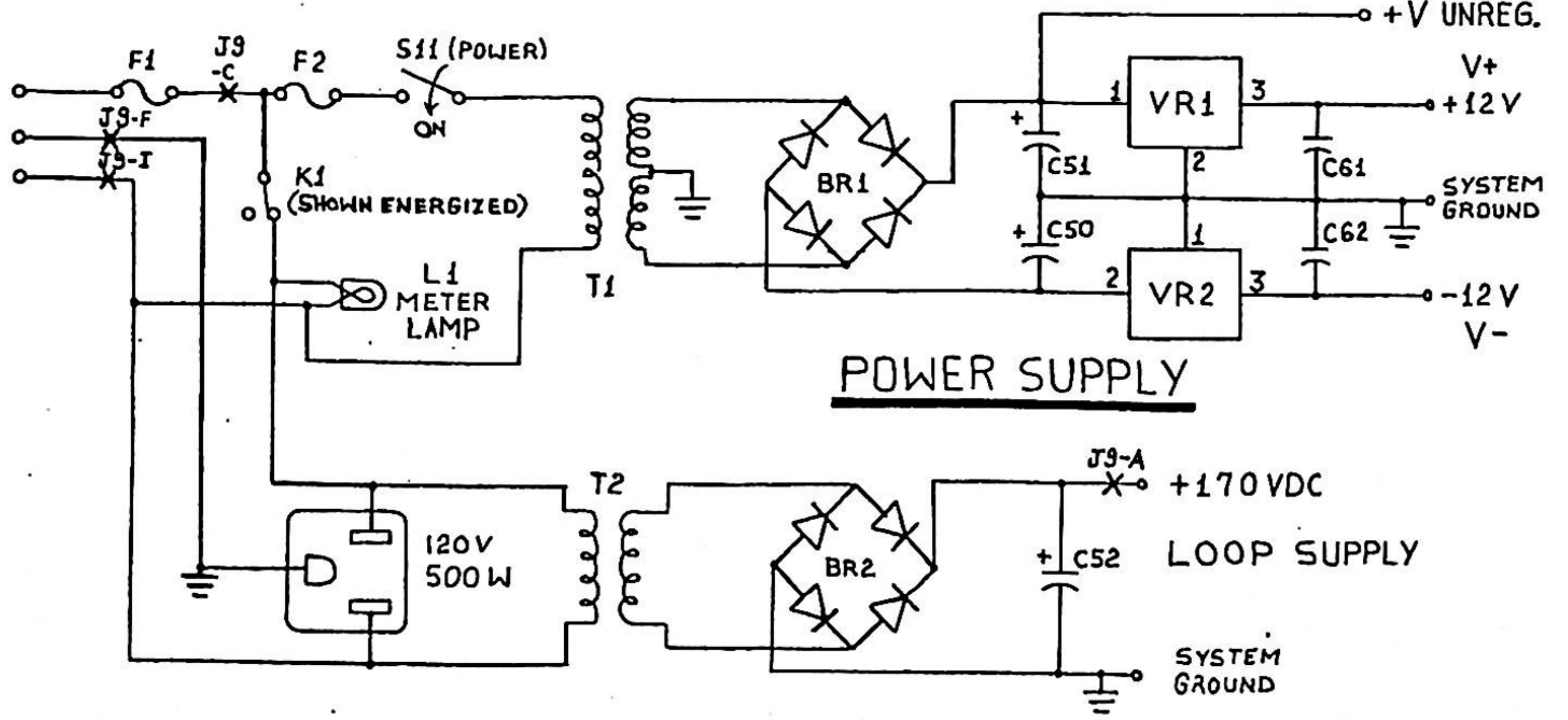

* These symbols designate resistors used in low cost FSK 1000.

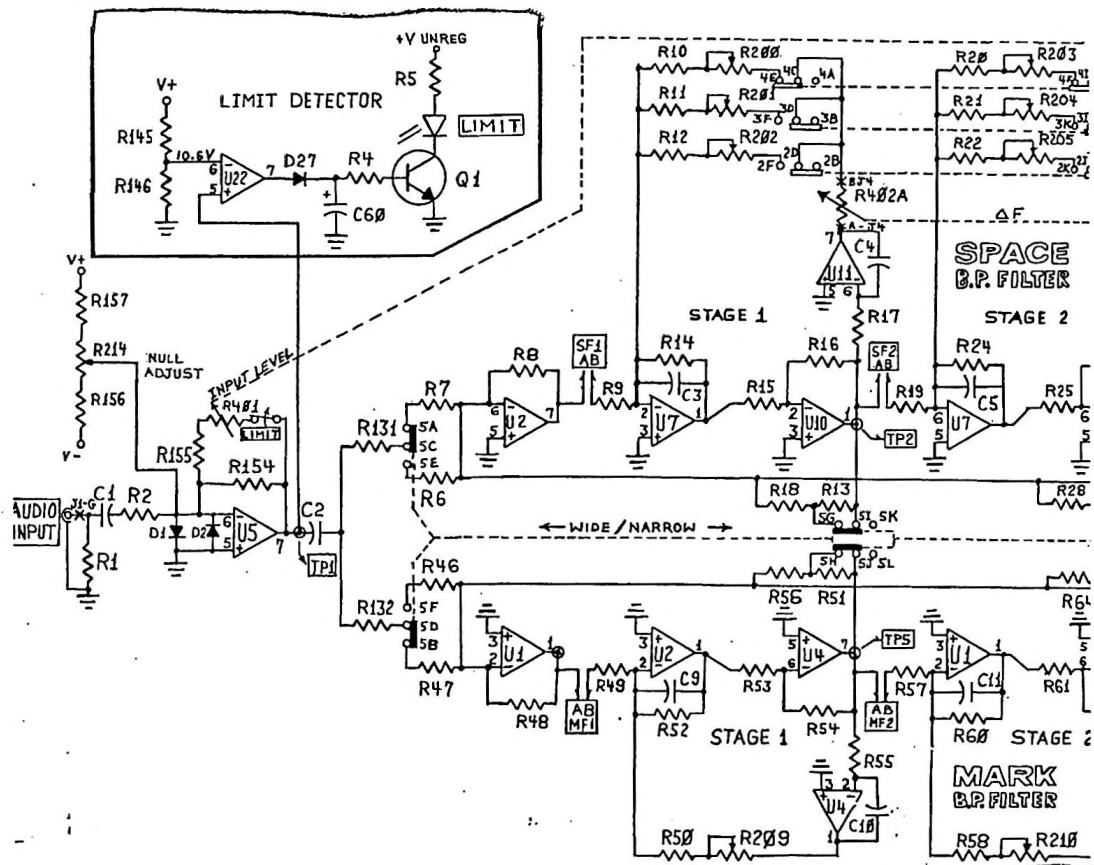

FSK-1000

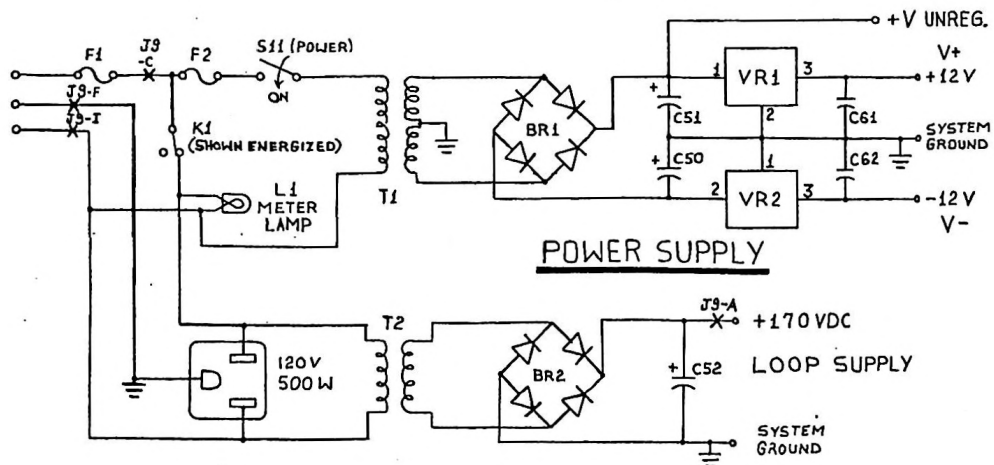

RESIST

R1	6
R2	4
R3	4
R4	4
R5	6
R6	1
R7	6
R8	2
R9	1
R10	1
R11	1
R12	8
R13	8
R14	3
R15	1
R16	1
R17	1
R18	1
R19	1
R20	1
R21	1
R22	8
R23	1
R24	3
R25	3
R26	1
R27	1
R28	1
R29	1
R30	1
R31	1
R32	8
R33	3
R34	3
R35	1
R36	1
R37	1
R38	2
R39	1
R40	1
R41	1
R42	4
R43	1
R44	1
R45	4
R46	1
R47	6
R48	2
R49	1

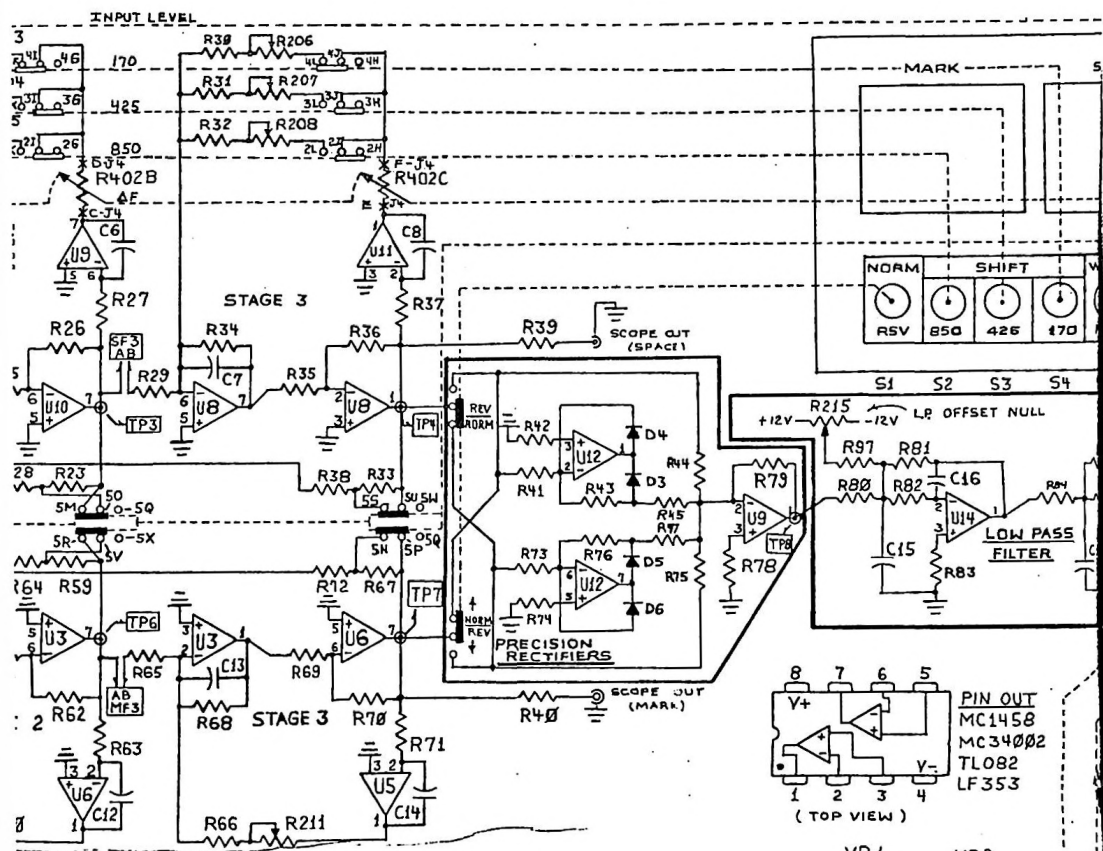

FSK 1000A PARTS LIST

RESISTORS

620	R50	2.15K(5.90K)	R100	46.4K	R150	1.00K
1.99K	R51	80.6K	R101	20.0K	R151	10.0K
4.99K	R52	317K	R102	20.0K	R152	562
4.99K	R53	10.0K	R103	20.0K	R153	562
42.0K	R54	10.0K	R104	46.4K	R154	1000
105K	R55	10.0K	R105	20.0K	R155	4.99K
6.49K	R56	13.3K	R106	5.90K	R156	46.4K
20.0K	R57	105K	R107	20.0K	R157	46.4K
105K	R58	2.15K(5.90K)	R108	105K	R158	105K
1.69K(3.57K)	R59	105K	R109	4.99K	R159	4.99K
1.30K(1.96K)	R60	317K	R110	10.0K	R160	3.57K
8.5 (1.30K)	R61	10.0K	R111	6.49K	R161	4.99K
80.6K	R62	10.0K	R112	10.0K	R162	317K
317K	R63	10.0K	R113	Deleted	R163	36.2K
10.0K	R64	13.0K	R114	317K	R164	100K
10.0K	R65	105K	R115	10.0K	R165	10.0K
10.0K	R66	2.15K(5.90K)	R116	20.0K	R166	1000
13.3K	R67	317K	R117	20.0K		
105K	R68	317K	R118	Deleted		
1.69K(3.57K)	R69	10.0K	R119	Deleted		
1.30K(1.96K)	R70	10.0K	R120	10.0K		
8.5 (1.30K)	R71	10.0K	R121	562		
105K	R72	2.9K	R122	499K		
317K	R73	10.0K	R123	71.5K		
10.0K	R74	1.99K	R124	562		
10.0K	R75	10.0K	R125	20.0K		
10.0K	R76	10.0K	R126	10.0K		
13.0K	R77	4.99K	R127	10.0K		
105K	R78	1.96K	R128	562		
1.69K(3.57K)	R79	10.0K	R129	32		
1.30K(1.96K)	R80	8.7K	R130	100K		
8.5 (1.30K)	R81	61.9K	R131	10.0K		
317K	R82	105K	R132	10.0K		
10.0K	R83	154K	R133	1.96K		
10.0K	R84	36.5K	R134	Deleted		
10.0K	R85	16.4	R135	10.0K		
10.0K	R86	16.2K	R136	317K		
2.9K	R87	105K	R137	10.0K		
105K	R88	10.0K	R138	36.2K		
10.0K	R89	Deleted	R139	150K		
10.0K	R90	10.0K	R140	10.0K		
4.99K	R91	Deleted	R141	317K		
10.0K	R92	317K	R142	105K		
10.0K	R93	154K	R143	4.99K		
4.99K	R94	317K	R144	4.99K		
105K	R95	Deleted	R145	1.30K		
6.49K	R96	46.4K	R145A	1.00K		
20.0K	R97	2ME1	R146	10.0K		
105K	R98	10.0K	R147	4.99K		
	R99	Deleted	R148	1.99K		
			R149	20.0K		

POTENTIOMETERS

RA01	1MEG
RA02	500 (2K)
RA03	100K

TRIMMERS

R200	500 (2K)
R201	500 (2K)
R202	500 (2K)
R203	500 (2K)
R204	500 (2K)
R205	500 (2K)
R206	500 (2K)
R207	500 (2K)
R208	500 (2K)
R209	500 (2K)
R210	500 (2K)
R211	500 (2K)
R212	2K
R213	DELETED
R214	2K
R215	2K

DIODES

D1 THRU D33	1N4148
Z1	1N750 4.7V

BRIDGE RECTIFIER

BR1	MDA100A
BR2	MDA100A

INTEGRATED CIRCUITS

U1 THRU U12	TL082, LF353 or MC34002
U13 THRU U25	MC1458, TL082 or MC34002

TRANSISTORS

Q1-Q3, Q5, Q7	2N2222
Q2 (FET)	2N3438

REGULATORS

VR1	MC7812CI
VR2	MC7912CI

RELAY

K1	28H113AE
----	----------

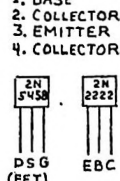
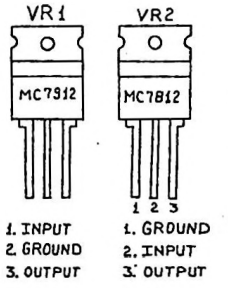
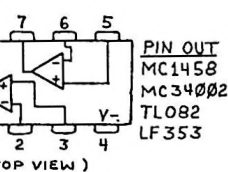

() These symbols designate resistors used in low cost FSK 1000.

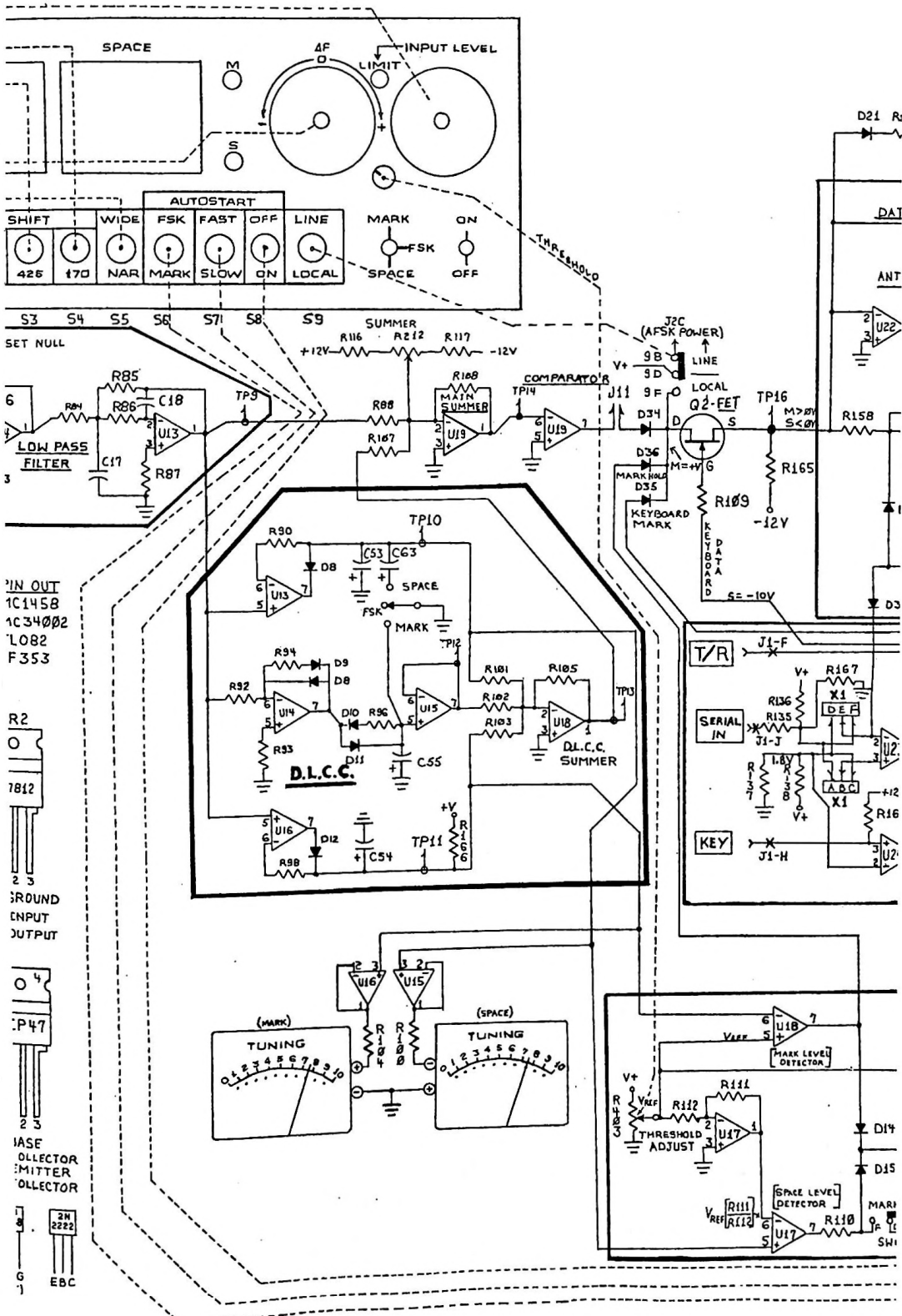

IN OUT
1C1458
1C34002
L082
F353

R2
7812
GROUND
INPUT
OUTPUT

P47
BASE
COLLECTOR
EMITTER
COLLECTOR
EBC

