

KG Glass Mount Antennas

IMPORTANT:

Read the instructions completely before attempting to install your Larsen Kulglass Antenna.

PRE-INSTALLATION TIPS

- Do not install KG2/70 on front windshield as glass is too thick.
- Avoid installing antenna on curved glass.
- Do not install on glass with metallic content (passivated glass i.e. "solar-coat," "solar-cool"). Check with auto manufacturer.
- Do not mount antenna on any dark tinted area or on an area where an aftermarket tinting film has been applied.
- Do not install over in-glass AM/FM dipole antenna.
- To install antenna over defroster wires, the wires must be spaced at least one inch or more apart. Center the antenna over one wire, allowing it to pass between the horizontal coupling plate (see Fig. 1).
- Clean glass with water and a mild detergent if needed. Do not use ammonia-based or similar type of glass cleaner.

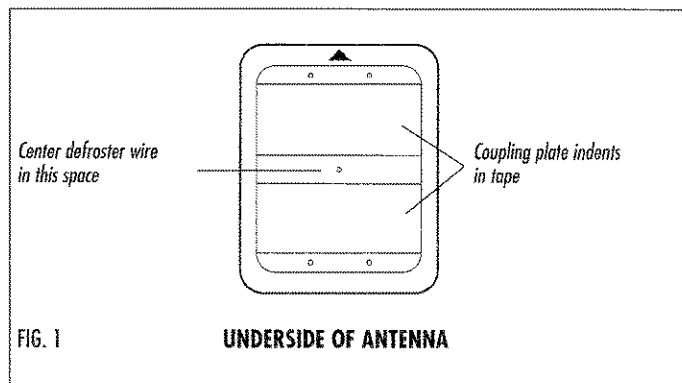

INSTALLATION

1. Vehicle glass should be near room temperature (70° F / 21° C) for installation.
2. Clean both inside and outside mounting areas with enclosed alcohol pad. Wipe off excess alcohol (do not allow alcohol to dry on the glass). If window film is apparent, use a mildly abrasive detergent-type cleanser.
3. Prepare outside mounting area by swabbing with enclosed liquid adhesion "enhancer." Allow enhancer to dry completely before applying outside coupler.
4. Peel protective liner from adhesive tape on the outside coupler. With the index arrow pointing up, mount the outside coupler starting at the top and rolling downward. From the inside of the window, observe whether the adhesive is making contact with edges and corners. Press firmly on all corners and in the center to ensure maximum contact. If the adhesive is not making contact, apply additional pressure where needed. Seal may be enhanced with a bead of clear silicone sealant. **Note:** 100% contact is not always possible with curved glass.
5. Remove protective liner from adhesive tape on inside coupler. With the index arrow pointing up, mount the inside coupler opposite of outside coupler.

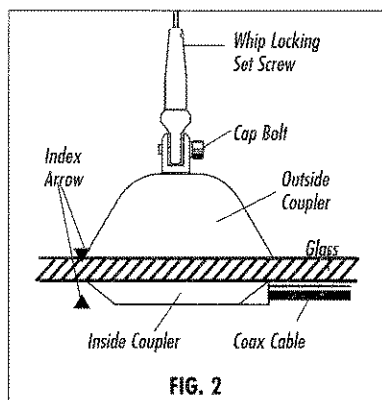

6. Route coax to the radio/phone. (Except KGB.)
7. Position swing arm and whip to the vertical position and tighten cap bolt at swing arm/coupler connection. (For best results, do not install whip or expose to water for 24-72 hours.)



Pulse warrants to every user of a Larsen product that it will perform to its specified ratings and will be free of defects in materials and workmanship.

Pulse will repair or replace without charge any Larsen product which fails to meet this warranty within one year of the purchase date. Excluded is failure due to misuse such as striking objects, improper installation, and use beyond specifications.

Pulse will not be responsible for any incidental or consequential damages due to failure of a Larsen product under this warranty or any implied warranty.

LARSEN - A Pulse Brand

3611 N.E. 112th Avenue
Vancouver, Washington 98682

Phone: 800-268-3662

360-944-7551

Fax: 360-944-7556

www.larsen-antennas.com

Larsen®, Kultra® and Kulduckie® are registered trademarks of Pulse Electronics.
Kulglass® Series U.S. Patent #4,764,773; KGB Series U.S. Patent #5,099,252; #5,155,494 - 11/99

KG Glass Mount Antennas



PI00085, REV. D, 02/11, 5190.2270

ANTENNA REMOVAL

1. To remove, use a broad, flat putty knife and gently work the blade between the window glass and the adhesive of the coupler.
2. After the couplers have been removed from the vehicle, clean the adhesive residue from the mounting surfaces using lacquer thinner and an absorbent, lint-free cloth, being careful not to damage foil contacts on the couplers.

ROD CUTTING DIRECTIONS

1. Remove rod from swing arm.
2. Cut rod to length.
3. Strip paint 3/4" from the end of the rod.
4. Install the rod back into the swing arm.
5. Tighten the set screw.

CUTTING CHART

KG144		
FREQUENCY	ROD LENGTH (IN)	(CM)
144 - 148 MHz	Factory Pretuned	
148 - 152 MHz	39 1/2	100.3
152 - 156 MHz	35	88.9
156 - 159 MHz	32 1/2	82.6

KG160		
FREQUENCY	ROD LENGTH (IN)	(CM)
160 - 163 MHz	Factory Pretuned	
163 - 167 MHz	34 1/2	87.6
170 - 174 MHz	30	76.2
172 - 176 MHz	28	71.1

KG440		
FREQUENCY	ROD LENGTH (IN)	(CM)
440 - 450 MHz	Factory Pretuned	
450 - 460 MHz	9 1/2	24.1

KG450		
FREQUENCY	ROD LENGTH (IN)	(CM)
450 - 460 MHz	Factory Pretuned	
460 - 470 MHz	9 3/4	24.8

KG470		
FREQUENCY	ROD LENGTH (IN)	(CM)
470 - 480 MHz	Factory Pretuned	
480 - 490 MHz	10	25.4

AMPS: 825 - 896 MHz **GSM:** 890 - 960 MHz **NMT:** 450 - 470 MHz

The following antennas come pretuned from the factory for optimum performance in your specified frequency range. No additional tuning is required. **DO NOT CUT RODS.**

MODEL	FREQUENCY
KG406	406 - 420 MHz
KG420	420 - 440 MHz
KG490	490-512 MHz
KG3E825	806 - 896 MHz
KG3E900	890 - 960 MHz
KGCP3E	824 - 896 / 1850 - 1990 MHz
KG2/70	VHF: 144 - 148 MHz UHF: 442 - 448 MHz